

# OBSERVATIONS OF DEPARTURE PROCESSES AT LOGAN AIRPORT TO SUPPORT THE DEVELOPMENT OF DEPARTURE PLANNING TOOLS

**Husni R. Idris, Bertrand Delcaire,  
Ioannis Anagnostakis, William D. Hall<sup>\*</sup>, John-Paul Clarke,  
R. John Hansman, Eric Feron, Amedeo R. Odoni<sup>†</sup>**

**Massachusetts Institute of Technology  
Dept. of Aeronautics & Astronautics  
77 Massachusetts Av., Room 33-409  
Cambridge, MA 02139**

## ABSTRACT

Field observations at Boston Logan International airport and data analyses comparing Logan to other major airports are conducted in order to identify the flow constraints that impede departure operations in an airport system. These observations and the associated analyses are discussed for each of the components of the airport system. It is concluded that the airport system is a complex interactive queuing system, that the different airport components contribute to cause delays and inefficiencies to different degrees, and that the runway system is the main flow constraint. The observations and analyses discussed reveal important implications for Departure Planning (DP) tools. The DP tools have competing objectives such as increasing the efficiency of the runway system, reducing delays and environmental impact, and maintaining acceptable workload levels and fairness. The interactions and dynamics between

the different components of the airport system determine how and where in the system the DP tools can reduce the delays and inefficiencies most effectively. Important interactions between the DP tools and other decision-aiding tools such as CTAS and SMA are also discussed.

## 1 INTRODUCTION

The Departure Planner (DP) is a concept for a decision-aiding tool that would help improve the departure operations performance at major congested airports. In order to achieve this goal one needs first to identify the constraints in the system primarily responsible for generating inefficiencies and delays. Once these primary constraints are identified, one needs to understand the dynamics of the system in order to determine where and how the system operations could be adjusted to mitigate the inefficiencies and delays. This would eventually determine the tools of the Departure Planner, their objectives, where in the system they should be introduced, and how they should be implemented. This paper reports some of the efforts to identify the flow constraints and the dynamics of airport systems

---

<sup>\*</sup> Research assistants, department of Aeronautics and Astronautics, Massachusetts Institute of Technology.

<sup>†</sup> Faculty members, department of Aeronautics and Astronautics, Massachusetts Institute of Technology.

based on observations and data analysis [IDRIS et al, 1998]. Some implications for the Departure Planner are discussed in conclusion.

## 2 FLOW CONSTRAINT IDENTIFICATION

The main purpose of this paper is to identify the flow constraints in the airport system. This is done using both observations at Boston Logan International Airport and data analyses including the ACARS (Aircraft Communication Addressing and Reporting System) delays reports by pilots and the ASQP (Airline Service Quality Performance) data which report landing, parking, pushback and takeoff times automatically through the ACARS system. These analyses and observations will be described for each of the components of the airport system. They include identifying major causes of delays in different components of the system and their interactions, identifying air traffic controllers' strategies to deal with the constraints, and identifying possible control points in the system where the impact of constraints could be reduced effectively.

### 2.1 The Airport System

Figure 1 depicts the main components of the airport system and the flow of aircraft, arrivals and departures, through these components. Each of the components, the runway system, the taxiways, the ramp, and the gates, constitutes a resource for which

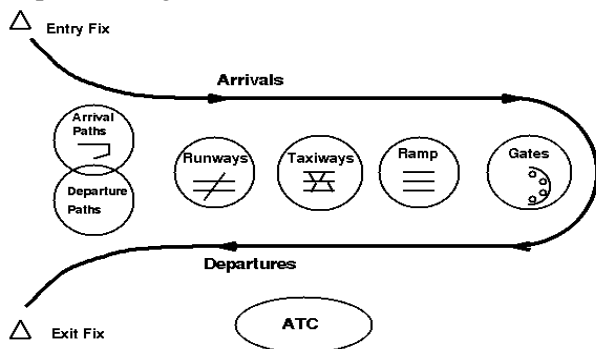

Figure 1: The airport system

the aircraft compete. ATC is also a resource of the system, where the aircraft have to flow through the

air traffic controllers in the form of the flight progress strips.

Each of these resources becomes a possible constraint to the flow of aircraft, where aircraft, physically and as flight progress strips, have to queue and wait to transition from one part of the system to the next.

### 2.2 The Runway as a Flow Constraint

The runway system is analyzed as a flow constraint using the ACARS delay reports and causal factors based on observations.

#### ACARS data analysis

Figure 2 shows the distribution of delay reports by pilots, for one major airline, over major delay cause categories. The pilot delay reports are available through ACARS, which is maintained by most major airlines. Using the ACARS system pilots voluntarily report the duration and cause of delays suffered under each of the specified categories. The data in Figure 2 include delay reports over a ten-month period for four major airports including Boston Logan. The reports in the Figure are for the delays incurred by departing aircraft between the pushback from the gate (the out time) and the takeoff at the runway (the off time).

The analysis of the ACARS data shows that the runway system is the main source of delay for departing aircraft. Figure 2 shows that for all four airports the delays incurred in the runway takeoff queue, represented in the Figure as the category “other flights landing and departing”, account for 55 to 70 percent of the total delays between pushback and takeoff. For DFW these delays amount to over 340,000 minutes. Each of the other categories accounts for less than 10 percent. The similarity in delay causes between the four airports indicates that other airports likely share the same behavior. The ACARS delay reports suffer from a number of limitations: They are subjective human reports, subject to human interpretations of the delay cause categories which may be vague and may overlap; and subject to human errors in estimating the delay times. They are also incomplete since they are voluntary

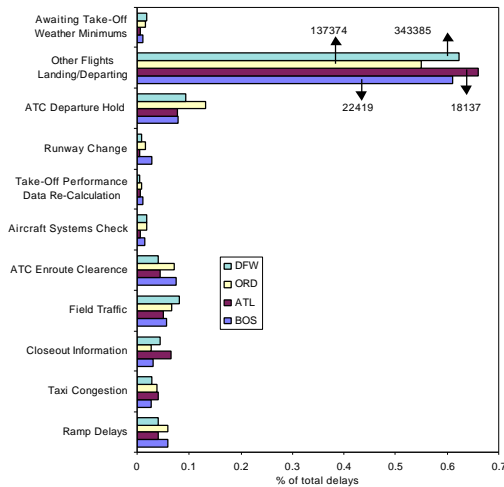

Figure 2: Normalized departure (Out to Off) delays (one airline: Jan-Oct 97)

reports by pilots. Despite these limitations, the vast difference between the delays attributed to waiting for other aircraft landing and departing at the runway and the other categories testifies to the fact that the runway system is the main flow constraint to departures in the airport system.

### Causal factors

There are many causes that contribute to making the runway system the major flow constraint, either by limiting the capacity of the runway system or by increasing the demand for it. Some of these reasons, supported by field observations at Boston Logan Tower are listed below:

- **Wake vortex separation requirements:** When aircraft land or takeoff, they occupy the runway not only for the time they are physically on the runway, but also for the duration it takes for the wake vortex they generate on the runway to subside. The time the next aircraft has to wait in the takeoff queue behind another aircraft that just landed or took off depends on the size of the two aircraft. These separations are more complicated and more restrictive when the runway is used for landings as well as takeoffs or when the runway configuration has dependent parallel or crossing runways. For example, a takeoff can start when the next landing on the same runway is at least 2 nautical miles from the runway threshold, or when a landing on an intersecting runway has cleared

the runway intersection point. These wake vortex separation requirements limit the capacity of the runway system. The capacity is limited further in bad weather conditions when the required separations cannot be waived and the configuration is limited to a smaller number of runways.

- **Scheduled demand:** The operations at the airport (both arrivals and departures) are usually metered by air traffic control such that the demand for the runway system is on average less than the effective capacity.

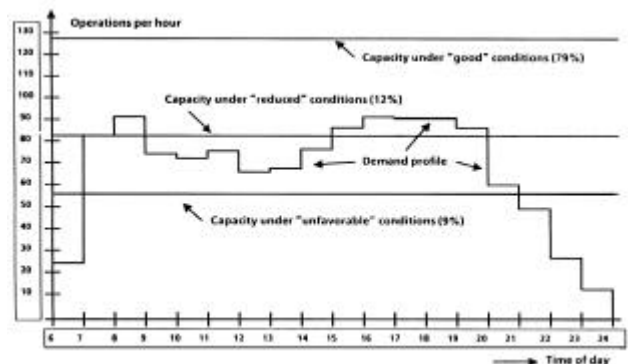

Figure 3: Demand vs. capacity at Logan airport (1987)

Figure 3 shows however that the demand may exceed the capacity at least sometimes during the day. This is due to overscheduling by airlines especially at rush hours or during hub bank operations, lower capacity of the runway system due to unforeseen occurrences such as weather, and the stochastic nature of the arrival process to the runway takeoff queue which is affected by a complex set of upstream processes at the gates, ramp and taxiway systems. It was observed that air traffic controllers try to switch to a high capacity configuration before the rush hours if weather permits. The high capacity configurations are the ones which use 3 runways at the same time, such as 22R for departures and 22L and 27 for arrivals, or the 4R, 4L, 9 configuration mentioned above (Figure 4).

- **Capacity limitations due to landing aircraft:** The runway resource providing service to the aircraft in the takeoff queue is sometimes shared by arrivals landing on the same runway or on dependent runways. When the runway is used for both landings and takeoffs, the effective capacity for departures is

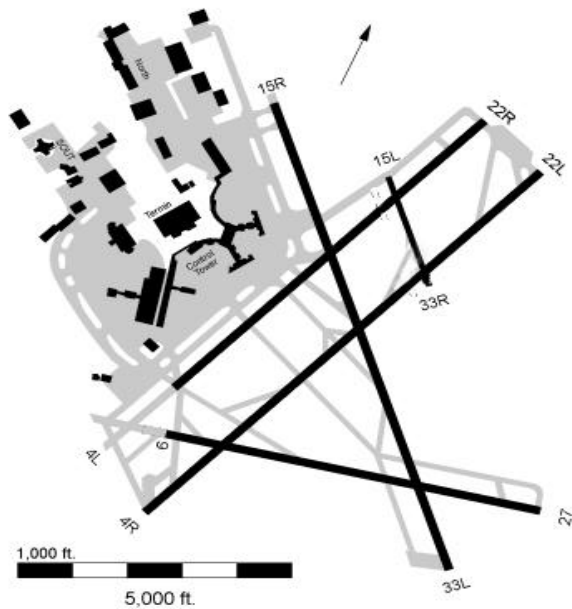

Figure 4: Map of Logan International Airport

reduced whenever the capacity for arrivals is increased. This trade-off between arrivals and departures is shown in the capacity envelope in Figure 5 below.

The curve approximates the Pareto frontier, which corresponds to the maximum capacity of the runway system achievable at the different combinations of arrivals and departures. This frontier can be determined theoretically or experimentally using simulations, given the wake vortex separations mentioned above and the fleet mix at the specific airport. The runway system usually operates

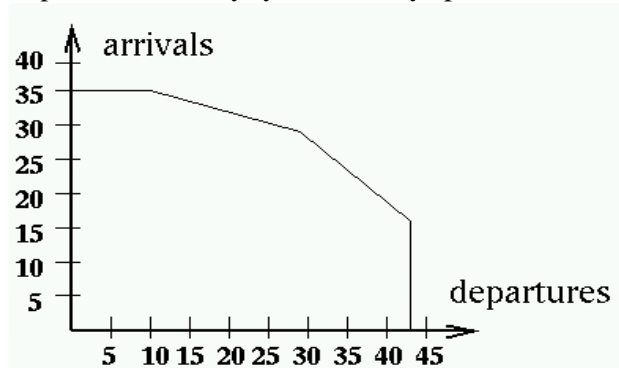

Figure 5: Capacity envelope of the runway system

at an effective capacity that is less than the maximum

given by the capacity envelope, depending on the current conditions [GILBO, 1991].

Air traffic controllers try to match the fluctuations in the arrival/departure mix in the demand, within the allowed tradeoff between arrivals and departures in a given configuration, or through a short-term configuration change. At Boston Logan Tower this is accomplished through coordination between the traffic management coordinator and the TRACON. Two of the tools used to effect changes in the arrival/departure mix when there is a relative departure demand increase, are metering for the arrival runway, and switching a runway from arrivals or mixed operations to departures exclusively, for the duration of the departure push.

- **Runway crossing:** The runway system is also shared by taxiing aircraft that have to cross an active runway. When departures have to cross an active runway used for arrivals, or arrivals have to cross an active runway used for departures, this introduces another coupling between the arrival and departure streams. For example in the 22R-22L-27 configuration described above (Figure 4), arrivals on 27 and 22L have to cross 22R in order to get to the terminal area. These arrivals queue on the taxiways between 22R and 22L, and when the taxiway segments become full the arrivals on 22L and 27 are impeded. The air traffic controllers in this case have to interrupt the departures on 22R in order to let the arrivals cross so that the flow of landings can continue.

- **Downstream constraints:** Restrictions on the flow of departures downstream of the runway may affect the runway operations. For example, it is common that aircraft are handed off to en-route sectors adjacent to the terminal area with in-trail separation requirements in order to control the flow into these sectors. This causes air traffic controllers to favor certain strategies for the departures from the runway in order to ease the process of establishing the in-trail spacing. At Boston Logan, one such strategy is to alternate jet and propeller aircraft departures, because jets usually fly on different initial departure paths than the propeller aircraft do. This increases the separation between successive departures heading towards the same point out of the

terminal area.

- **Noise:** A dominant downstream constraint at Boston Logan Airport, are the noise regulations, which restrict operations above certain populated areas. This is an additional factor taken into account by the controllers in adopting strategies for managing departure flows.

- **Delays due to aircraft preparation:** A number of taxi checks are performed by each aircraft before takeoff. These include final weight and balance calculations, systems checks, cabin checks, and deicing in bad weather. An aircraft may be delayed by these processes and hold the rest of the takeoff queue.

- **ATC workload constraints:** Under heavy traffic conditions, the controllers are forced to adopt strategies that ease their workload, while unable to use alternative strategies that may reduce runway waiting time. ATC workload will be discussed in more detail later.

### 2.3 The Gates as a Flow Constraint

The gates are analyzed as a flow constraint using the ACARS delay reports and causal factors based on observations.

#### *ACARS data analysis*

Figure 6 shows the distribution of the delay reports by pilots through the ACARS system for the arrival phase between landing (the wheels on time) and parking at the gate (the in time). These data are for the same airline, period, and airports as the data in Figure 2. The distribution shows that for most airports there is a dominance of the delays due to gate congestion (gate occupied) over the other delay categories, such as ramp and field congestion. Although the dominance is not as prominent as it is in the case of the delays due to the runway system, it is very clear for the Boston and Chicago airports.

#### *Casual factors*

- **Gate capacity:** There is a limited number of

gates available for each airline, which makes the gates a scarce resource. Observations show that some airlines over schedule their gates at Boston Logan, and use hangar positions to store the aircraft in excess of gates.

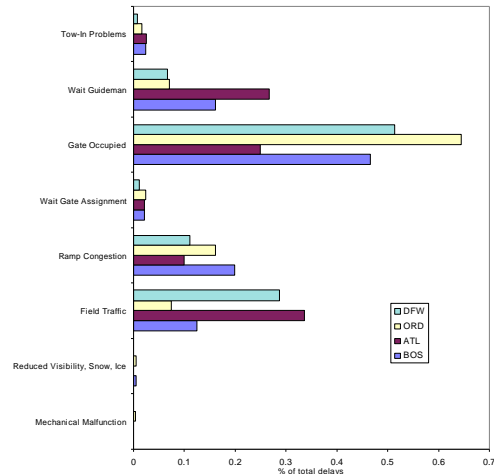

Figure 6: Normalized arrival (On to In) delays (one airline: Jan-Oct 97)

- **Sharing gates between arrivals and departures:** Like the runway system, the gates are another airport resource where arrivals and departures interact. As indicated in the ACARS delay data in Figure 6, large delays are incurred by arriving aircraft when their assigned gate is occupied by a departure. This may occur either because the arrival is early or because the departure is late in pushback.

- **Interdependence between gates:** Aircraft have to wait for each other when they pushback into the same alley. This makes coordinating pushback operations complicated particularly at airports like Boston Logan where the terminal geometry is constrained (Figure 7). At Logan, because the alleys are shared by more than one airline which compete for pushback, the coordination of pushback is done through the tower based on a strict First-Come-First-Serve (FCFS) rule. At most other airports, however, the airlines' stations control the gates and the ramp area.

- **Interdependence between gates and ramp/taxiways:** As shown in Figure 7, some of the

gates at Boston Logan pushback directly onto the taxiway system, blocking the taxiway for the duration of pushback and engine startup. Also when an arriving aircraft finds its gate occupied it must wait on the taxiway leading to the gate. This coupling introduces more constraints on the gate operations, and led to the pushback from such gates to be under the control of the tower. This also

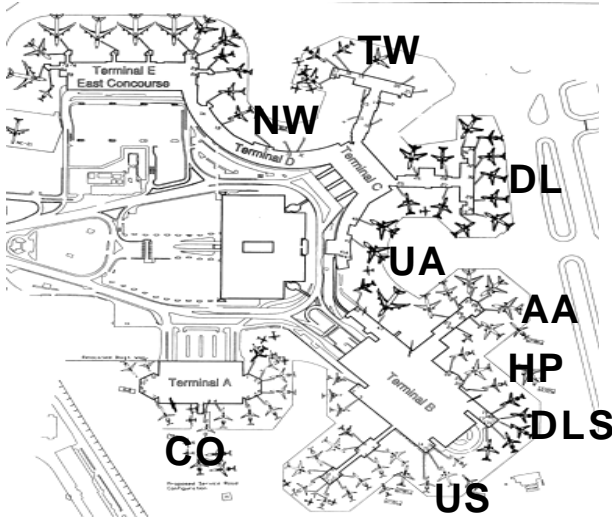

Figure 7: Boston Logan Airport gates

emphasizes the importance of holding pads where aircraft can wait without holding the traffic stream on the taxiways and ramp. Such holding pads are non-existent at Boston Logan making the gate/taxiways coupling more crucial.

- Turnaround operations:** While on the gate, aircraft undergo a very complex set of operations to turn it around from an arrival to a departure. Based on observations and interviews with pilots and air traffic controllers, these operations are depicted in Figure 8 in the form of a Petri Net analysis, showing the processes that are required to get the aircraft to the state of 'ready for pushback'. The circles represent conditions or states of the aircraft and other elements of the system, and the bars represent transitions of state, which may be time-consuming processes. Arcs leading from circles to transitions indicate that the conditions represented by the circles must be satisfied before the transition occurs. Once the transition occurs the states represented by circles

with arrows coming from the transition are satisfied. Each of the processes in the turnaround contributes to the uncertainties and possible delays that may take place as the aircraft is on the gate. The turnaround operations are managed by the airline's station at the airport. The air traffic controller (the gate controller in the case of Boston Logan) receives a call from the pilot only after all the turnaround operations are completed to indicate that the aircraft is either 'ready for pushback' or 'ready for taxi', depending on the airport, and this becomes his/her only observable state.

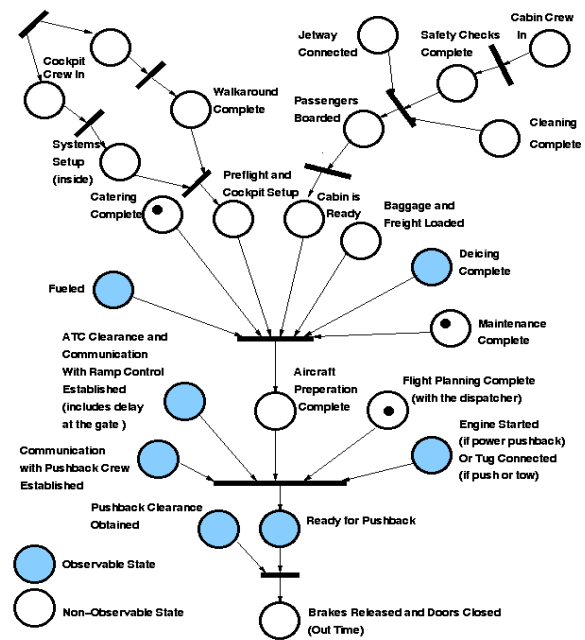

Figure 8: Turnaround Operations

Then the gate, ramp, or ground controller (depending on the airport tower configuration) delivers the pushback clearance to the pilot, the aircraft transitions to the state of 'brakes released and doors closed', and the pushback can commence. However, prior to the call for pushback, the air traffic controller has limited observability on many aircraft states (except possibly for deicing or fueling where the air traffic controller may be able to observe the process from out the window). This prevents him/her from accurately predicting the time of 'ready for pushback', which is the first time that the aircraft is introduced into the ATC system and the departure process is initiated.

Looking at the complexity of the turnaround processes on the gate (Figure 8), it is evident how difficult it is for this controller to predict exactly how many aircraft will call 'ready for pushback' in the next few minutes. Compared with the arrival process, the air traffic controller, or the decision aiding tool e.g. CTAS [ERZBERGER, 1990, 1991] observes the arrival stream proceeding toward the runway and monitors the position and the speed of each aircraft on the radar screen. This makes the flow of arrivals a more observable process where, the air traffic controller can predict the arrival sequence and time quite early and accurately.

Based on the comparison between the different prediction time constants of arrivals and departures, it is hypothesized that the availability of advance departure flow information is essential for better planning of the departure process. The Surface Movement Advisor (SMA) [LAWSON, 1998], which provides some departure delay information to the air traffic controllers, is currently being successfully tested at Atlanta Hartsfield Airport as an information source that assists departure planning. The provision of such information increases the predictability of the departure demand and supports more highly coordinated departure operations.

- Downstream constraints:** Departures are often held at the gate to meter the flow downstream. This includes the ground hold and miles-in-trail spacing imposed by Flow Control to meter the arrivals into some destination airports that are experiencing capacity limitations. Aircraft are held on the ground to reduce the possibility of more expensive delays in the air. Most of the ground hold is absorbed at the gate before pushback (or in holding pads if available). Departures are also held at the gate by air traffic controllers to meter the flow to the taxiways and the runway system within the same airport. One information feedback mechanism that the air traffic controllers use to estimate downstream congestion levels and the workload level of adjacent controllers is observing the flight progress strips. For example, the gate controller often holds departures at the gate when he/she observes the ground controller overwhelmed by an excessive pile of flight strips.

## 2.4 The Ramp and Taxiway Systems as Flow Constraints

The ramp and taxiways provide a network of routes which the aircraft, arrivals and departures, use to connect between the runways and the gates. While aircraft interact with each other and with other vehicular traffic at intersections, most of the time spent on the ramp and taxiways is waiting for a runway or for a gate. The ramp and taxiways therefore, provide buffer space for aircraft to queue for takeoff, for runway crossing, and for a gate that is occupied or blocked, as pointed out from earlier observations.

### A queuing system

The ramp and taxiway systems can be considered as (or are essentially) a system of queues that leads the departures from the gates to the runways. The capacity of the runway system, given all the constraints mentioned above, determines the service rate for departures and the throughput limits. The taxi out time, which is the time each departure spends between pushback and takeoff, can be considered the time that each departure spends in the queuing system. This time includes both actual taxiing time and time spent waiting in the takeoff queue (and other queues such as at runway crossings). Figure 9 [DELCAIRE, 1998] shows the correlation between the taxi out time and the number of departures, which already pushed back but have not taken off and

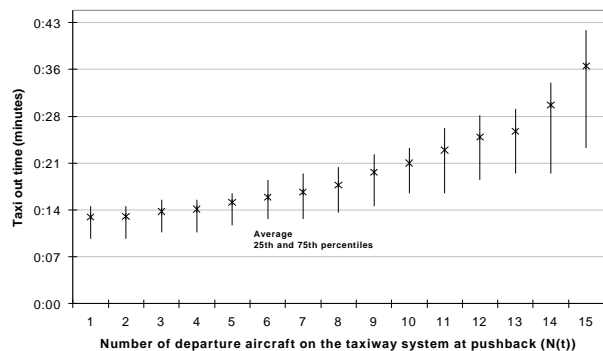

Figure 9: Taxi-out time as a function of the number of departing aircraft on the taxiway system at Boston Logan Airport. (Source: ASQP data for January-March 1997)

therefore, are waiting in the queuing system, for Boston Logan. The correlation reflects the behavior of a queuing system where the waiting time and the number of departures in the queue are related by the departures' arrival rate. The taxi out time in the Figure is approximated by the difference between the 'wheels off' time and the 'brakes released and doors closed' time, both times are recorded automatically (by activated switches) through the ACARS system. These times are available through the ASQP data, maintained by the FAA, which also include the 'wheels on' time and the parking at gate 'in' time also recorded automatically through the ACARS system. In [SHUMSKY, 1995], it is also indicated that as the taxi out time increases (and therefore, the lengths of the departure queues) the throughput increases up to a limit due to the capacity limitation.

Figure 10 below [DELCAIRE, 1998], shows the high variability of taxi out times for jet operations at Boston Logan Airport. This distribution was constructed using ASQP data from January through March 1997. Results for the Southwest sample (4L-4R-9 configuration) are also highlighted.

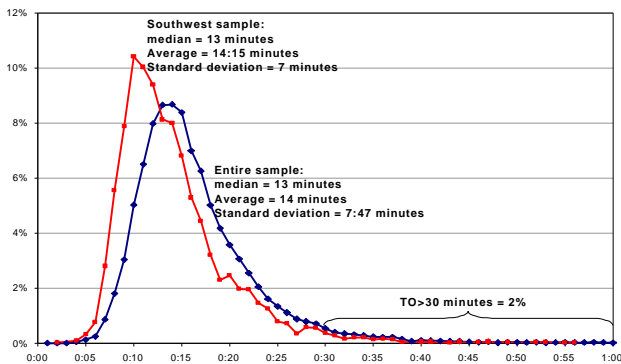

Figure 10: Distribution of Taxi Out Time (in hour:min) for Boston Logan Airport

### Queuing dynamics and control point identification

The take-off sequence at the runway is constructed along the path from the gate to the runway. Affected by the dynamics of the airport system, this sequence may be modified anywhere between the gates and the runway. The input to output relationship is analyzed from the ASQP data in order to identify the dynamics of the system between these two points. However,

these data are available for the major participating airlines only. Therefore, the analysis conducted here is limited to the dynamics of their operations only, which involve primarily jet aircraft. Despite this limitation, considerable insight into the dynamics of the system is gained. The times of pushback and take-off reported in the ASQP data are sorted and the sequences are generated. The sequence of pushback is compared to the sequence of take-off, and the number of position swaps between the two sequences is determined for each departure. Figures 11 and 12 show the swap magnitude histograms for Boston and Atlanta. Figure 11 shows that for Logan airport, almost 40 percent of the departures did not change their sequence position between the gate and the runway, and on average a jet departure undergoes a one-position swap. Therefore, the dynamics of the departure sequence for Logan appears to be a single FCFS after the aircraft are pushed back from the

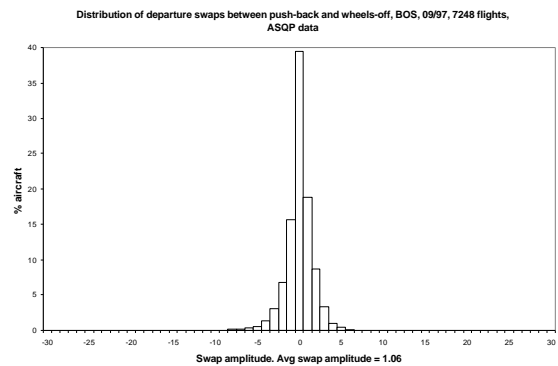

Figure 11: Histogram of the swap magnitude at Logan airport

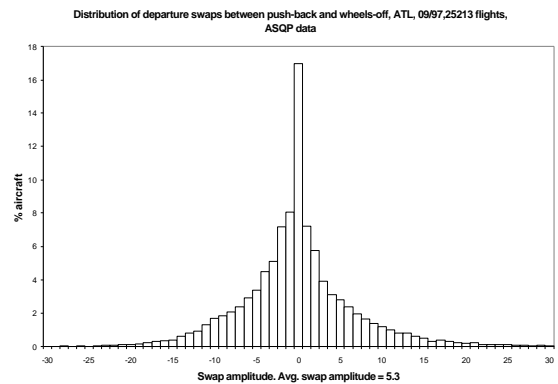

Figure 12: Histogram of the swap magnitude at Atlanta airport



gates. On the other hand, Figure 12 shows that at Atlanta only about 15 percent of the jet departures do not undergo any position swaps in their pushback sequence, while on average, jet departures and the runway. This indicates that at Atlanta experience a swap of 5.3 positions between the gate the dynamics of the departure sequence are not FCFS. An alternative interpretation is that at Atlanta, there is more opportunity to change the departure sequence after pushback from the gate than at Logan airport.

Figure 13 shows the average swap magnitude for 6 airports analyzed. It is clearly demonstrated that the dynamics of the airport system between the gates and the runways, limited to the jet operations, are different for the 6 airports analyzed.

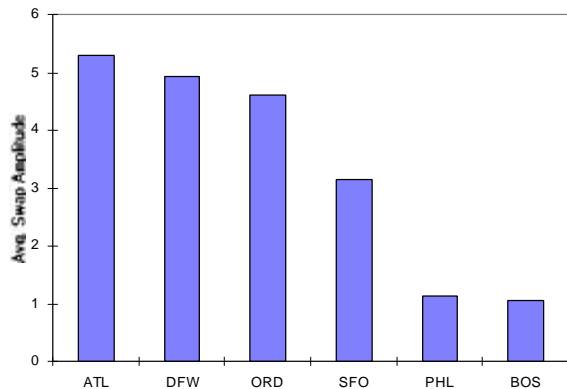

Figure 13: Average swap amplitude at the 6 airports studied

Simple models are generated for airport systems based on the insight gained from the analysis above and the airport geometry. Airport systems similar to Boston Logan are modeled with a gate pool and a runway system as shown in Figure 14.

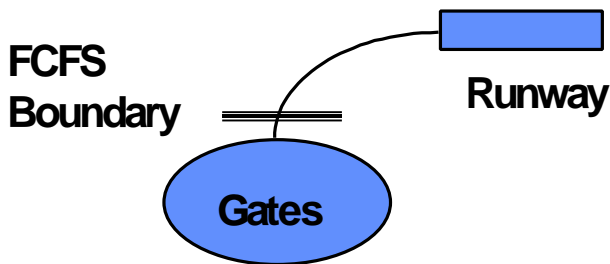

Figure 14: Single runway – single buffer airport system

Once departing aircraft push back from the gate pool they join a FCFS queue at the runway. Therefore, a single control point exists at the pushback from the gate, located at the FCFS boundary. The pushback sequence completely determines the take-off sequence, and control action to affect the efficiency of the runway must be taken at the gate.

As shown in Figure 4, the Logan airport terminal area is close to the runway system and once aircraft are pushed back from the gates they are essentially in the takeoff queue. There is no separate ramp area and little space to reorder the aircraft after pushback. In fact there is no ramp control position in the Boston Logan Tower.

The Atlanta airport shown in Figure 15 has two runway systems on opposite sides of the terminal area. Aircraft are pushed back in different directions depending on their runway system and are held at the ramp exits where a sequencing decision is made for each runway system. In Figure 16 a queuing model for such an airport system is shown with a ramp area associated with each runway set. The path to the runway and the pushback sequence are chosen at the gate, while each ramp offers an additional opportunity to affect the sequence at each runway.

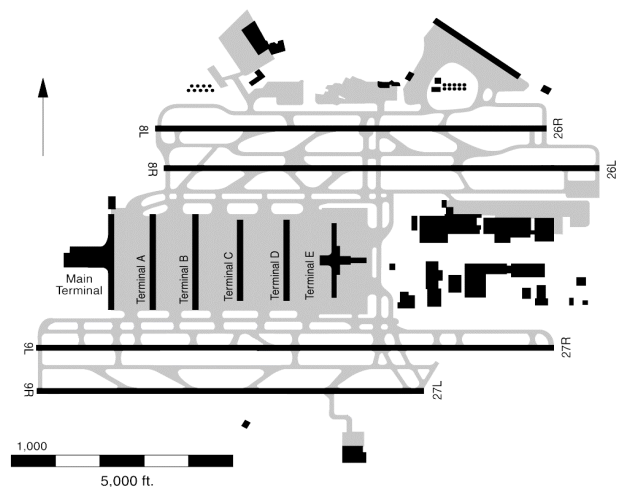

Figure 15: Map of Atlanta Hartsfield international airport

Comparing ATL and BOS in Figure 13, we may hypothesize that another possible cause for the difference in the swapping behavior between these

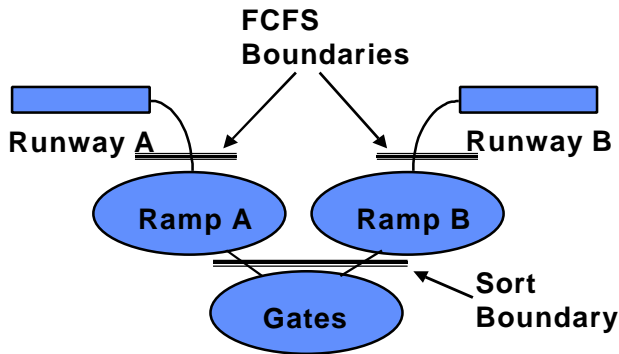

Figure 16: Dual runway – dual buffer – dual path airport system

two airports is the hubbing schedule of ATL, which is not observed in BOS. However, despite the fact that PHL is a hub airport, it exhibits similar swapping behavior to BOS, indicating that the reordering opportunities are more dependent on the geometry of the airport than on the schedule

Note that the models presented above are simplified. More variations and combinations can be developed to model several different airport systems.

## 2.5 ATC Workload and Human Factors

As aircraft flow through the airport system between the gates and the runways they are constantly under the control of the ATC tower. The number of air traffic controllers in the tower depends on the geometry and the size of the airport. In general however, a gate controller controls the gates, a ramp controller controls the ramp area, a ground controller controls the taxiways, and a local controller controls the runways, as indicated in Figure 17. At Boston Logan for example, there is no ramp controller since most of the gates pushback right onto the taxiway system, and there are one or two local controllers depending on the runway configuration. There are also a flight data position who receives the flight plan and prepares the flight progress strips for each aircraft prior to the gate position, and pre-clearance delivery and gate hold positions which are usually handled by the gate position at Boston Logan.

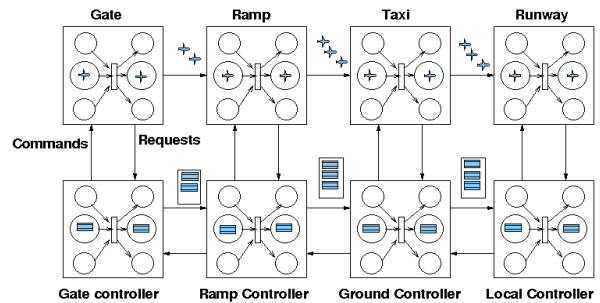

Figure 17: Aircraft/flight strip parallel processes

The air traffic controllers communicate with each other mainly through the flight progress strips. Before an aircraft can move from the control area of one controller to the control area of another controller, the controller hands the aircraft's corresponding flight progress strip to the next controller manually, and asks the pilot to switch to the frequency and communicate with the next controller. There are therefore, two parallel and coupled processes as shown in Figure 17: The flow of the aircraft in the airport coupled with the flow of the corresponding flight progress strips in the tower. As aircraft queue on the surface of the airport, the corresponding flight strips queue on racks in the tower waiting for the controllers attention.

As the congestion level increases the flight progress strips pile up in front of the controllers and the workload level of the controllers increases. This was evident during observations at the Boston Logan Tower, where during the departures peak, the level of communication between the controllers and the pilots increased tremendously. The ground controller for example, would start grouping the commands issued to aircraft, delivering several pushback clearances followed by several handoffs to the local controller, thus attempting to improve the task and communication efficiency. It was also observed that the state of the flight strips piles (or queues) is used as a feedback mechanism to indicate the workload level of the controllers. For example, the gate controller would start holding aircraft at the gate, when observing an excessive buildup of flight strips waiting for pushback clearances before the ground controller. The ground controller sometimes explicitly asks the gate controller to slow delivering departures when overloaded.

### *Head-down time*

Except for the gate controller, controllers observe the state of the aircraft and queues in the airport by continually scanning out of the window and the radar screens. On the other hand, the gate controller is mainly occupied with flight data and other information obtained through a computer station. This has important human factors' implications when developing computer based automation tools such as the departure planner. It implies that the gate position might be most suitable for placing such a tool without significant effects on the controllers' workload. This observation is particularly relevant for Boston Logan, where as indicated by the queuing analysis, the departure processes are best controlled at the gate position before joining the FCFS takeoff queue.

## **2.6 Environmental Issues**

In observing the large buildup of takeoff queues on the taxiways at Boston Logan Airport, issues of environmental impact emerged. One such impact is the high level of ozone emissions attributed to taxiing aircraft with their engines running. Such types of environmental impact are a major consideration in planning departure operations.

## **3 CONCLUSIONS AND IMPLICATIONS FOR THE DEPARTURE PLANNER TOOL**

Based on the observations and analyses presented a number of conclusions and implications for the Departure Planner tool are discussed below:

- **The airport is a complex interactive queuing system:** It is concluded from the observations and the analyses presented in this paper that the airport system is a complex queuing system, where aircraft share the limited resources at the gates, ramp, taxiways and runways as well as the ATC resources in the tower. As the aircraft compete for these resources queues build on the surface of the airport, as well as in the tower in the form of flight strips. These limited resources become potential flow constraints, which impede the flow of aircraft through

the system. The system is rendered more complex by the interactions between the different constraints, where a problem in one part of the system, including the tower, can rapidly propagate and cause congestion at other parts of the system.

While departure operations are the main concern of the departure planner tool, it is evident from the observations presented here that there is a large degree of interaction between arrivals and departures on the surface of the airport. Arrivals and departures share many of the same resources in the airport, and arrivals are often given priority over departures due primarily to safety reasons. This is different than the operations in the terminal area where arrivals and departures are separated procedurally using different routes and altitudes. The departure planner tool therefore, does not have the same ability to consider departures separately from arrivals, as does CTAS for example, in concentrating solely on merging the arrivals in the terminal area and the final approach.

- **The runway is the main flow constraint:** Through the flow constraint identification it was determined that there are key constraints to the flow of the departure operations, especially at the runways and gates and in the human factors associated with air traffic control. Of these the runway system emerged as the main flow constraint and cause of delay. This implies that the effort of the departure planning would be most beneficial if targeted at maximizing the performance of the runway system. To do so however, the interactions and the complex nature of the airport system just mentioned should be taken into account in order to determine where and how such an effort should be carried out. To that end the dynamics and control points identification contributes.

- **DP objective function:** In trying to assist air traffic controllers to plan departure operations, the Departure Planner tool must also take into account the varying objectives of all different agents involved in and affected by airport operations (control tower and TRACON, airlines, passengers and surrounding communities). This makes the definition of the objective function for DP a hard problem. Based on the observations and analyses presented, preliminary identification of the main objectives is outlined:

- Maximize the airport operational efficiency and the runway throughput
- Maintain the appropriate balance between arrivals and departures
- Minimize departure delays
- Minimize the environmental impact of emissions and noise by minimizing aircraft taxi-out time
- Maintain fairness
- Reduce controllers' workload
- Provide flexibility to airlines to define and satisfy their own objectives

There are many issues that make the definition of the above objectives difficult, such as the definition of fairness and the definition of delays and assessment of their associated costs. The workload of the air traffic controllers is also an important issue. As observed and demonstrated by other decision-aiding tools such as CTAS, air traffic controllers are not willing to accept an increase in their workload level.

- **Control points and functions:** The swap analysis and control points identification indicate that the structure of the queuing system and the points where the queues are controlled depend on the airport. In the case presented comparing Boston Logan to Atlanta Hartsfield, it is hypothesized based on the swap analysis, that Boston is a one departure queue system, such that aircraft join the FCFS departure queue after the pushback. In such a system departure sequencing should be controlled at the gate. On the other hand, Atlanta has multiple runway systems with at least two departure queues, and a controlled ramp area for each such that there are multiple points where the departure queues can be controlled.

- **Strategic implications:** At a more strategic level a configuration planning function is required to respond to the demand for runway capacity, given the limitations imposed by weather and environmental concerns, such as noise restricted space. Short-term fluctuations in the arrival/departure demand mix are managed through short-term configuration changes as well as relative holding of arrivals and departures. These functions are performed at the level of the Traffic Management coordinator and the supervisor in coordination with the TRACON.

- **Interaction with other automation tools:** It is essential for the development of the departure planner tool to identify its relation with the other automation tools introduced in the terminal area, such as CTAS and SMA. CTAS assists in merging the arrivals to the final approach. It is essential therefore, for providing information to the departure planner about the arrival demand. Given the high level of interaction between arrivals and departures on the airport surface, this information is important for DP, especially for configuration planning and balancing the arrival/departure mix. In addition DP has important inputs to CTAS both in terms of leaving space in the arrival stream to accommodate departure demand, and in terms of transmitting preferences for arrivals based on gate availability. The latter is essential for future applications which would consider gate availability as a factor in ordering the arrivals traffic. The value of SMA was already pointed out in Section 3.3 with respect to forecasting departure demand. The Petri Net analysis of the gate operations showed the volatility and difficulty to predict the short-term departure demand. SMA, by providing information about these operations in the form of departure delays, can assist DP in predicting the departure demand more timely and accurately.

## 4 ACKNOWLEDGEMENTS

This research was supported in part by NASA, under grant NAG 2-1128. The authors would also like to acknowledge the cooperation and courtesy of the Boston Tower and TRACON in providing access for field observations.

## 5 REFERENCES

- DELCAIRE, B., FERON, E., *Dealing with Airport Congestion: Development of Tactical Tools for the Departure Flows from a Large Airport*, SM Thesis, Technology and Policy Program, M. I. T., Cambridge, MA
- ERZBERGER, Heinz [1990] *Integrated Automation Tools for the Center and TRACON*, the Journal of ATC, Oct.-Dec. 1990, vol. 32, no.4, pp. 90-91

ERZBERGER, H., T.J.DAVIS, S.M. GREEN [1993], *Design of Center -TRACON Automation System*, AGARD meeting on Machine Intelligence in Air Traffic Management, Berlin, Germany, May 11-14

GILBO, Eugene [1991] *Airport Capacity Estimates for Various Weather Conditions*, ATMS/ETMS Project Memorandum, Unisys Corporation and Volpe National Transportation Systems Center, Cambridge, MA

GILBO, Eugene [1993] *Airport Capacity: Representation, Estimation, Optimization*, IEEE Transactions on Control Systems Technology, 1, pp. 144-154

IDRIS, Husni et al., *Identification of Flow Constraint and Control Points in Departure Operations at Airport Systems*, AIAA 98-4291, pp.947-956 in proceedings of the AIAA Guidance, Navigation and Control conference, Boston, MA, August 1998

LAWSON, Dennis [1998] *Surface Movement Advisor*, Journal of ATC, January-March, pp. 25-27

SHUMSKY, Robert Arthur [1995] *Dynamic statistical models for the prediction of aircraft take-off times*, PhD. Thesis Operations Research Center, MIT, Cambridge

STAMATOPOULOS, M. A., K. G. ZOGRAFOS and Amedeo R. ODONI [1997] *An Analytical Model for Runway System Capacity Analysis*, Proceedings of IFAC International Transportation Symposium, Chanea, Greece

VENKATAKRISHNAN, C. S., Arnold BARNETT and Amedeo R. ODONI [1993] *Landing Time Intervals and Aircraft Sequencing in a Major Terminal Area*, Transportation Science, 27, pp. 211-227

VRANAS, Peter [1992] *The Multi-Airport Ground Holding Problem in Air Traffic Control*, Ph.D. Thesis, Operations Research Center, M. I. T., Cambridge, MA